

## FB DIFFUSER



### 1. GENERAL INFORMATION

Diffuser installed on FB units increase outlet air speed. As a result heated air reaches occupied area faster. It is recommended to use diffuser when the FB units are installed under the ceiling on the high level.

### 2. TECHNICAL DATA

Material: powder coated sheet steel  
 Colour: dark gray (RAL 9007)  
 Weight: 3,8kg  
 Available to: LEO FB NEW 25 / 45 / 65

Diffuser mounted on FB unit causes 10% drop of air volume and heat output in relation to nominal parameters.

### 3. DIMENSIONS

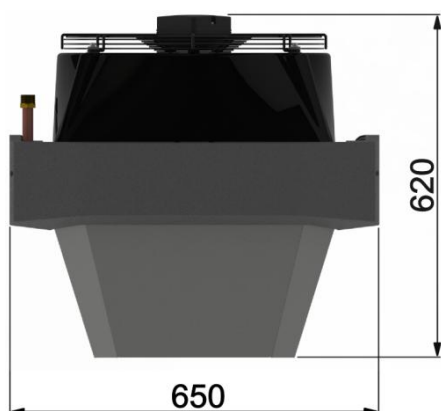

### 4. RECOMMENDED MOUNTING HEIGHT

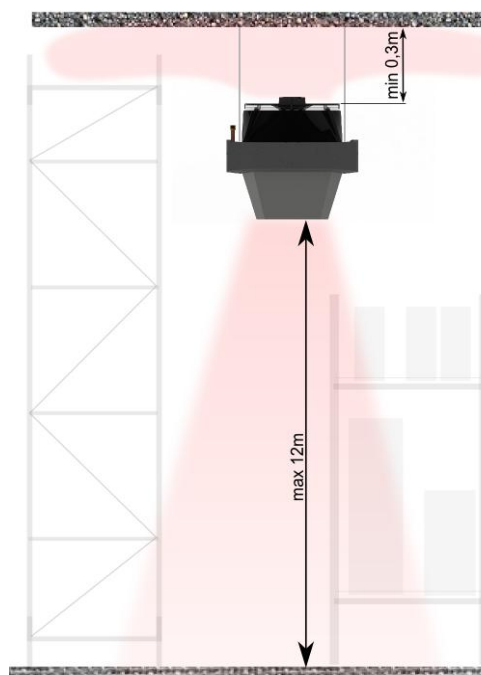

## 5. NON-ISOTHERMAL RANGE FOR LEO FB WITH DIFFUSER

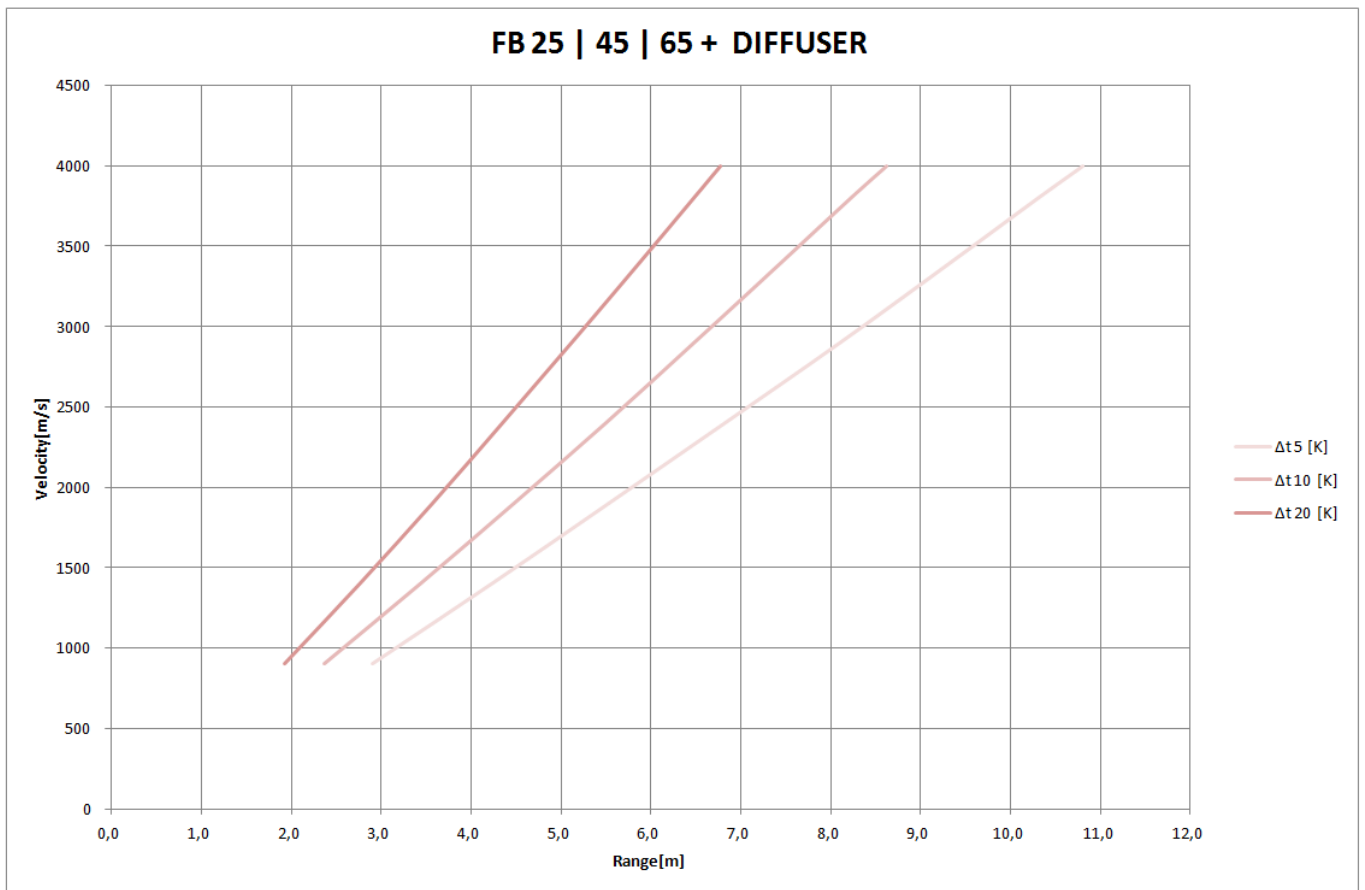

## 6. INSTALLATION

